

CS8812

3 channel series connected LED driver

General Descriptions

The CS8812 is a 3-channel constant current LED drive with resumable data transfers and internal display patterns. There are three open-drain constant current outputs, with a built-in PWM of grayscale. The range of input power is from +9V to +15V, and voltage-endurance of LED port is +12V. There is a built-in 12bits GAMMA correction module. PWM maximum refresh frequency is 8kHz. The CS8812 use the e RZ (extended return to zero code) as the signal transmission mode, which can control the output current channel by channel and cascade infinitely. CS8812 provides two-signal data input as redundant control, which ensures the transmission of the signal if any single chip damages. In the absence of signal input, CS8812 displays the built-in display patterns that is suitable for those applications without a controller. There is the built-in power-on and power-off protection in the drive, which can enhance the service life of the chip. It also has the automatic test function while power on, which is convenient for the customer to test. The CS8812 provides SOP8 packaging, working environment is from -40 ° C to + 85 ° C.

Applications

- LED Display
- LED lighting/light engineering

Typical Applications

Features

- 12v operating supply voltage with 7805 module inside
- Default 17.5mA constant current output, the minimum is 11mA
- Use e-RZ code, serial data frequency 800kHz
- 8bits data transfer, 12bits build-in GAMMA correction of PWM display
- Built-in PWM technology, supports 8kHz PWM refresh rate
- With resumable data transfer function, single chip damage does not infect data transmission
- Built-in display pattern for the applications without a controller
- Built-in automatic test mode, power-on and power-off protection
- ESD: 2kV
- working environment is from -40 ° C to + 85 ° C
- Packaging: SOP8

Order Information

Number	Packaging Info.	
CS8812	SOP8	4000PCS/Reel
	SOP8	100PCS/Strip

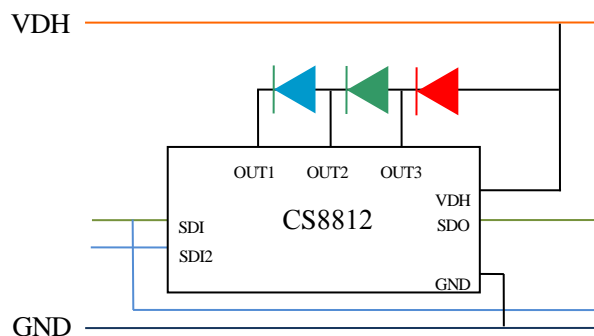

Block Diagram

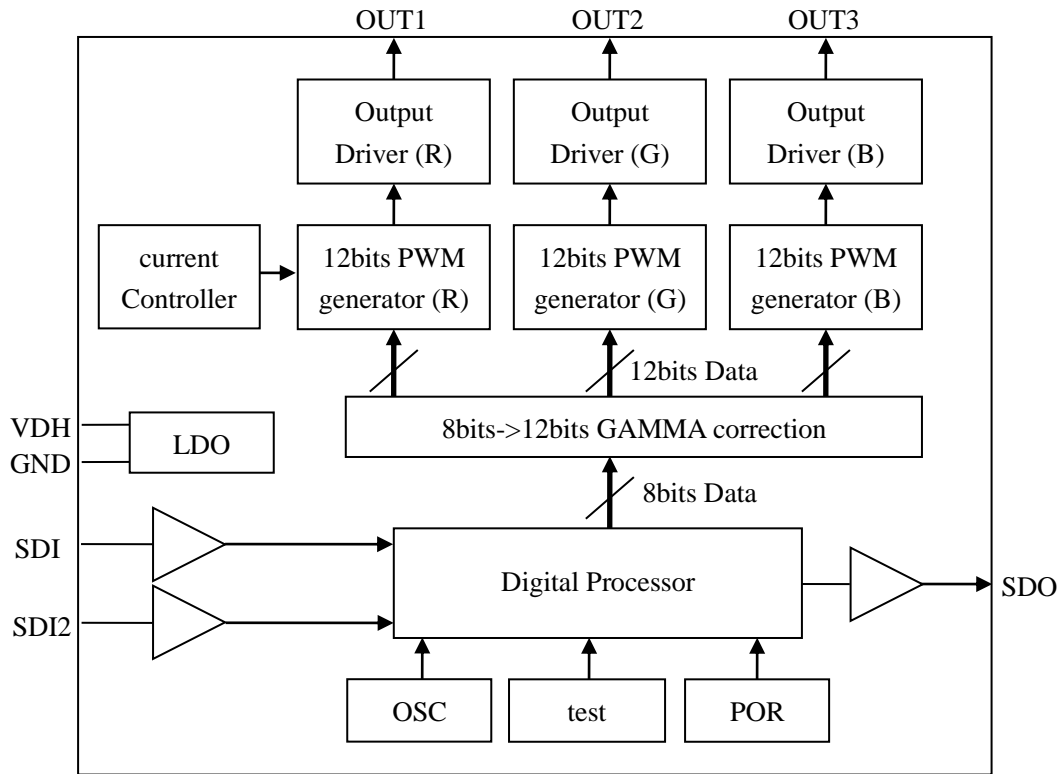

Pin Configuration

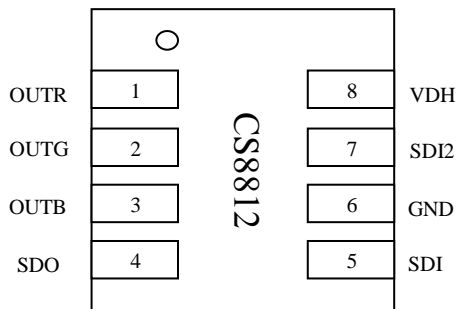

Pin Configuration with LED

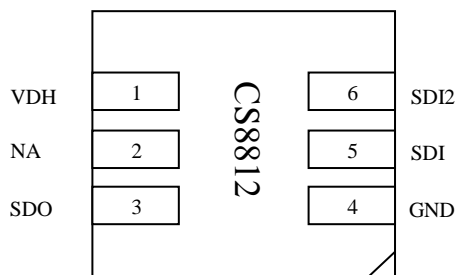

Pin Description

Pin name	type	Function
VDH	P	12V Power Supply
GND	P	Chip Ground
OUTR.....OUTB	OUT	Constant-current outputs, connected to LED
SDI	IN	Series data input
SDI2	IN	Redundant series data input
SDO	OUT	Series data output

Equivalent Circuits of Input and Output

1 SDI/SDI2

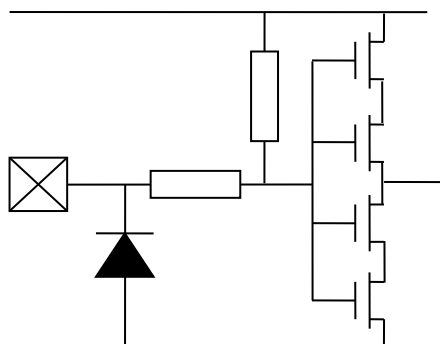

2 SDO

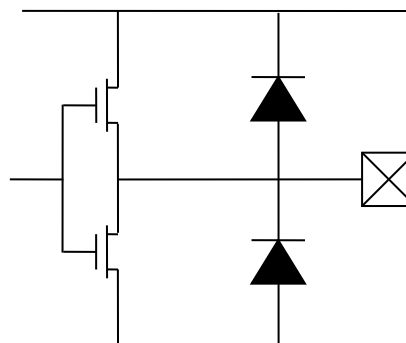

3 OUTR、OUTG、OUTB

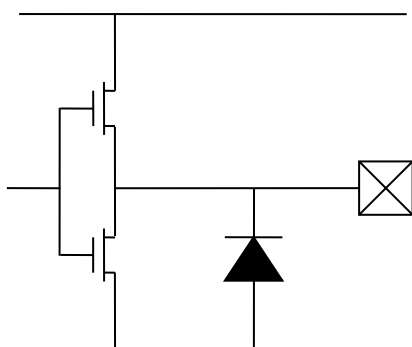

Maximum Ratings

Characteristic	Symbol	Maximum Working Range	Unit.
Power Source	VDH	-0.4~15V	V
On-chip Power Source	VCC	-0.4~6V	V
Input Logic Voltage	SDI	-0.5~VDH+0.5	V
Maximum output current	IOUT	18	mA
Output voltage-endurance	VDS	15	V
Ground current	IGND	55	mA
Power dissipation	Pd	400	mW
Working temperature	TOP	-40~85	°C
Storage temperature	Tstg	-55~150	°C
ESD	HBM	2000	V

(1) Stresses above these ratings may cause permanent damage. Exposure to absolute maximum condition for extended periods may degrade device reliability. These are stress ratings only and functional operation of the device at these or any other condition beyond those specified is not supported.

(2) All voltage values are with respect to ground terminal.

Electrical Characteristics

Characteristic	Symbol	Symbol	Measuring condition	Min	Typical	Max
Power supply	VDH		9	12	15	V
internal Power supply	VCC		4	5	6	V
High Input Logic Voltage	VIH		4			V
Low Input Logic Voltage	VIL				1	V
Output current	IOUT	VDH=12V	11	15		mA
Static current	Ichip			2.5		mA
Power dissipation	Pd				150	mW
Current variation(channel)	dIOUT	I _{out} = 15mA, V _{out} = 1.2V		±1.5%	±3%	%
Current variation(chip)	dIOUT2			±3%	±6%	%
Current offset VS Power Source				NA		
Voltage range of outputs	VOUT			1.2	12	V
External Power Res	Rvdh	VDH=12V		50		ohm
External Power Cap	Cvdh		0.1			uF

Switching Characteristics

Characteristic	Symbol	Measuring condition	Min	Typical	Max	Unit.
Internal Oscillator Frequency	OSC			25		MHz
PWM refresh rate				8		kHz
Data refresh rate				30	1017	Hz
Data refresh delay time		1024 points		700		us
Internal program data refresh rate				100		Hz
Channel output delay time				80		ns
Current output rising time		18mA, VOUT=1V		40		ns
Current output falling time				40		ns
PWM pulse duration				240		ns
RZ data frequency			400k	800k	1M	Hz

Typical Application

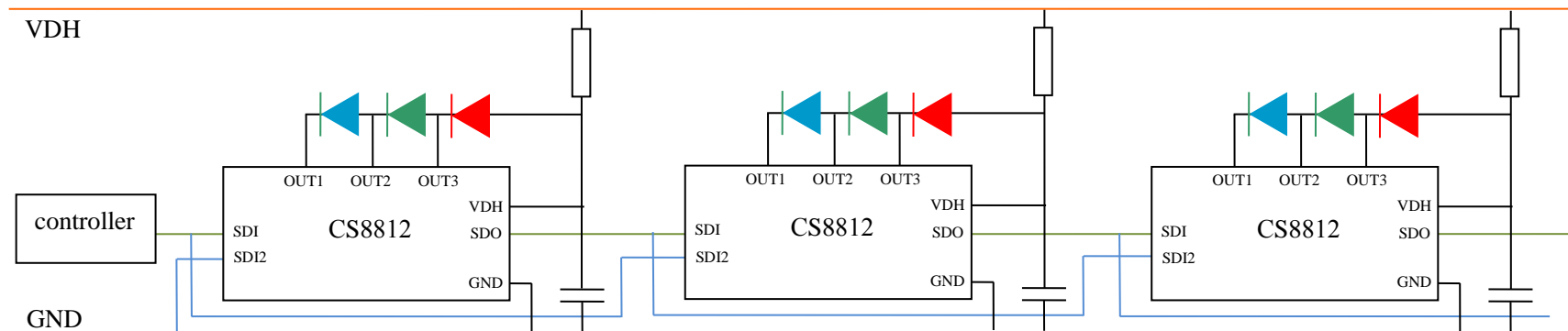

Data Format

CS8812 adopts the extended return to zero code (e-RZ) data transmission mode, 8bits data for single channel, each IC supports 3 channel for display. The transmission data is filtered internally to support the data anti-jitter function. The extension type is compatible with the traditional RZ code. So it is suitable for most of the RZ code controller in the market.

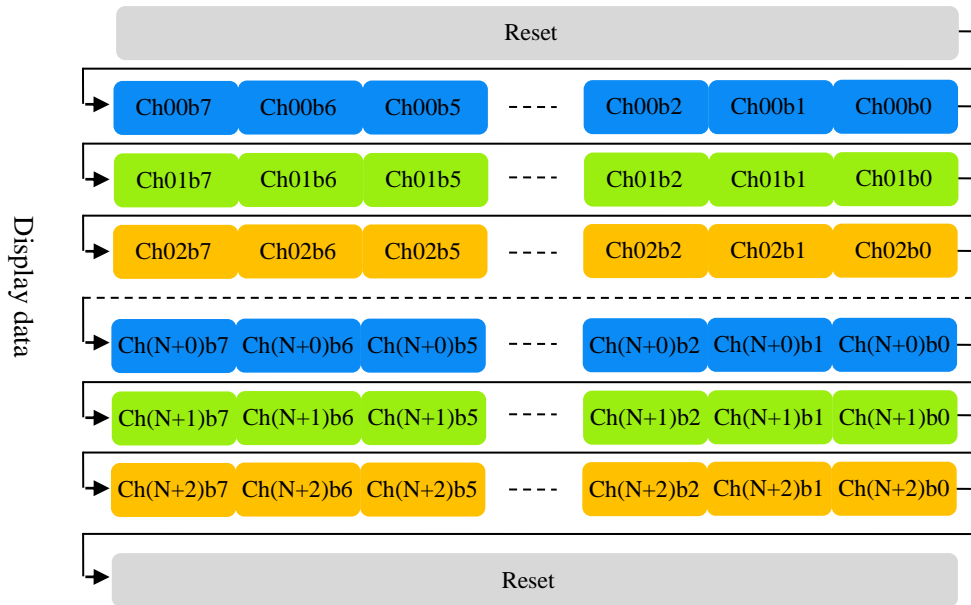

Single code with 1:3 duty cycle and a standard 800kHz transmission speed. The maximum frequency can reach 1MHz. CS8812 re-code the data before transmission. Data delay is less than 0.7us from chip to chip, meets the dynamic image needs.

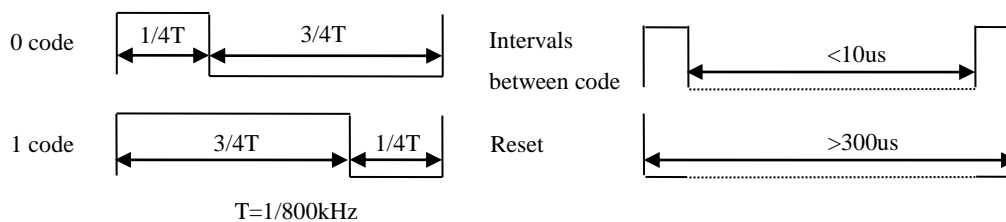

Dual channel redundant control

Dual channel redundant control can be used to effectively avoid the failure of any single device damage, and reduce the damage rate of the driving system to one millionth. The SDI signal is used as the default transmission channel while the system is power on. The transmission channel priority is switched between SDI and SDI2 when the transmission data is abnormal. The device will choose the clear transmission channel after data detection.

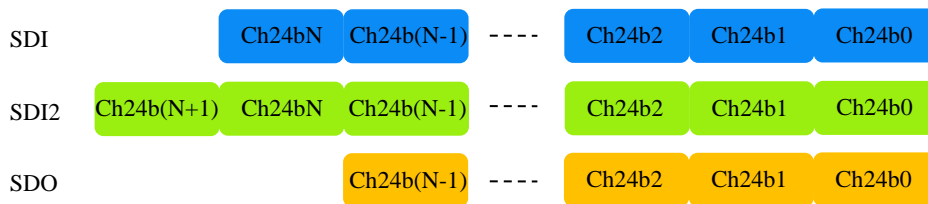

When the external control data is transmitted, SDI uses the 1-24bits received data as the display data, meanwhile, SDI2 will discard the 1-24bits data and use 25-48bits data as the display data.

Data channel status testing during production

In the production process, any one of the abnormal data channel will not affect display because the chip uses dual SDI input. It is difficult to detect the problem data channel during the production process, which may cause the dual channel is equivalent to a single channel.

In order to avoid this situation, the status of the data channel can be detected by using the test controller in the external control situation. While any channel appears Weld, short, open or other abnormal communication, the chip will display in white to facilitate the detection of problem position.

Working principle of the series structure LED controller

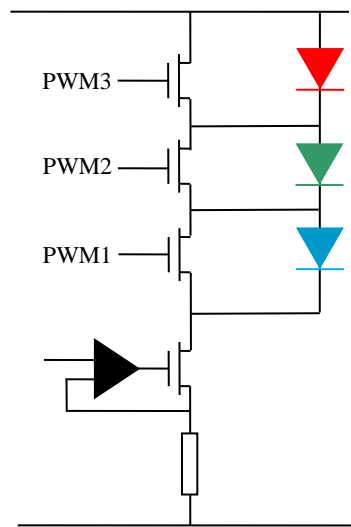

It is RGB LED series structure. Power supply voltage is 12V, and the LED constant current is 18mA. Different to the parallel architecture of 5V power supply and 54mA drive current, the series architecture can provide a better drive ability. The new architecture's total drive current is only 1/3 of the original one, and $V_{ds}=4V$. The power loading ability is better.

In the series structure mode, when the internal MOS paralleling with the LED is open, the current flow into the LED and the LED lights. When the internal MOS paralleling with the LED is short, the current flow into the MOS device and the LED close. Switching the MOS device by PWM signal can lights on or off the LED.

Stagger output delay

In order to prevent the large power interference from the LED switching, reduce the power circuit voltage fluctuations, CS8812 has a built-in output hysteresis function. OUT1, OUT2, OUT3 will work in accordance with the 80ns interval sequence, to improve the system's anti-jamming performance. Meanwhile, the current peak output stagger will reduce the system EMI radiation, to meet environmental requirements.

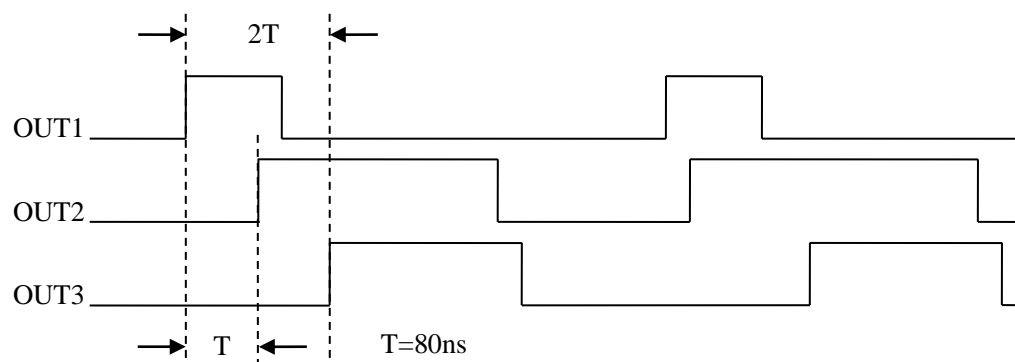

MPWM (multi-PWM)

In order to increase the refresh rate of PWM output, MPWM adopts a unique method of dispersibility to distribute the periodic N in the display time, as shown in the figure below. CS8812 adopts MPWM technology, and the PWM refresh rate increases to 8kHz, which shows gentle effect and does not affect the accuracy of output current.

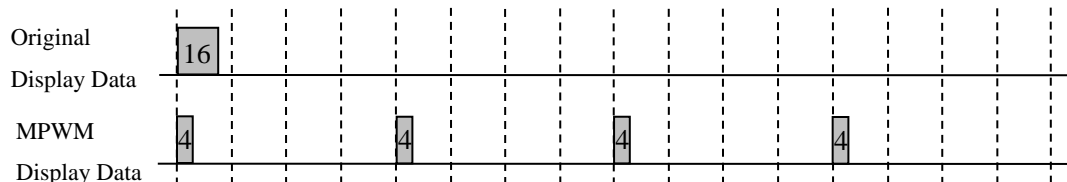

Internal control patterns

CS8812 gets into RGB test mode right after power on. If the device does not receive the external display data for a long time, the chip will go into the built-in display patterns mode. Pattern on a total of six categories of 32 series, including integral color jump, integral color gradient, meteors, waves, colorful gradient, color jump of water circulation. It is 10 minutes about, and the image refresh frequency is 100hz.

Under the internal display mode, the first chip's SDI/SDI2 needs to be connected to GND.

Power dissipation

When all the three output channels are turned on, the practical power dissipation is determined by the following equation:

(Vout represents the output terminal voltage when the current is turned on; Duty represents the ratio of the time at which the current is turned on)

$$PD(\text{practical}) = V_{cc} \times I_{cc} + V_{outA2} \times I_{outA2} \times \text{DutyA2} + \dots + V_{outD0} \times I_{outD0} \times \text{DutyD0}$$

In secure operating conditions, the power consumption of an integrated chip should be less than the maximum permissible power dissipation which is determined by the package types and ambient temperature. The formula for maximum power dissipation is described as follows:

$$PD(\text{max}) = \frac{T_j(\text{max})(C) - T_a(C)}{R_{th(j-a)}(C/Watt)}$$

The PD (max) declines as the ambient temperature rises. Therefore, suitable operating conditions should be designed with caution according to the chosen package and the ambient temperature. The following figure illustrates the relation between the maximum power dissipation and the ambient temperature of the SOP8 package.

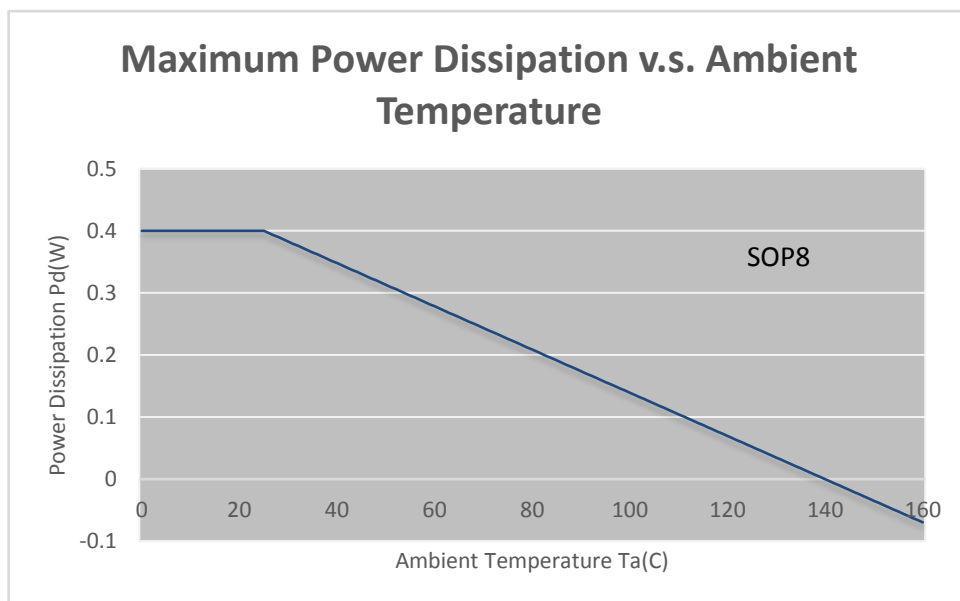

Package Outline Dimension

SOP8

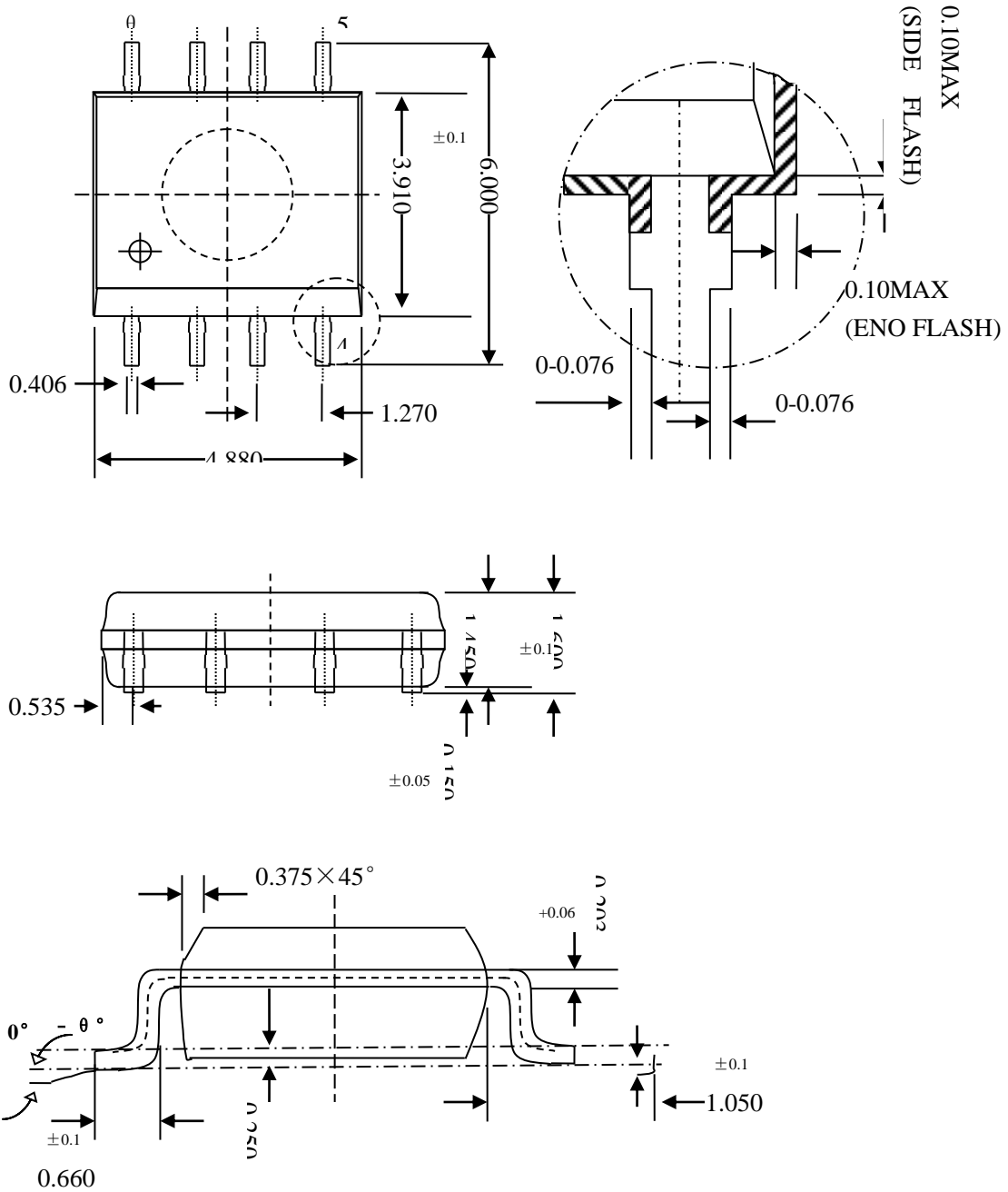

The products listed herein are designed for ordinary electronic application, such as electrical appliances, audio-visual equipment, communications devices and so on. Hence, it is advisable that the devices should not be used in medical instruments, surgical implants, aerospace machinery, nuclear power control system, disaster/crime-prevention equipment and the like. Misusing those products may directly or indirectly endanger human life, or cause injury and property loss.

Genesis Technology will not take any responsibilities regarding the misuse of the products mentioned above. Anyone who purchases any products described herein with the above-mentioned intention or with such misused application should accept full responsibility and indemnify. Genesis Technology and his distributors and all their officers and employees shall defend jointly and severally against any and all claims and litigation and all damages, cost and expenses associated with such intention and manipulation.