

DMX/RDM High Volt LED Strip Controller

09.218HP.04263



Important: Read All Instructions Prior to Installation

Function introduction

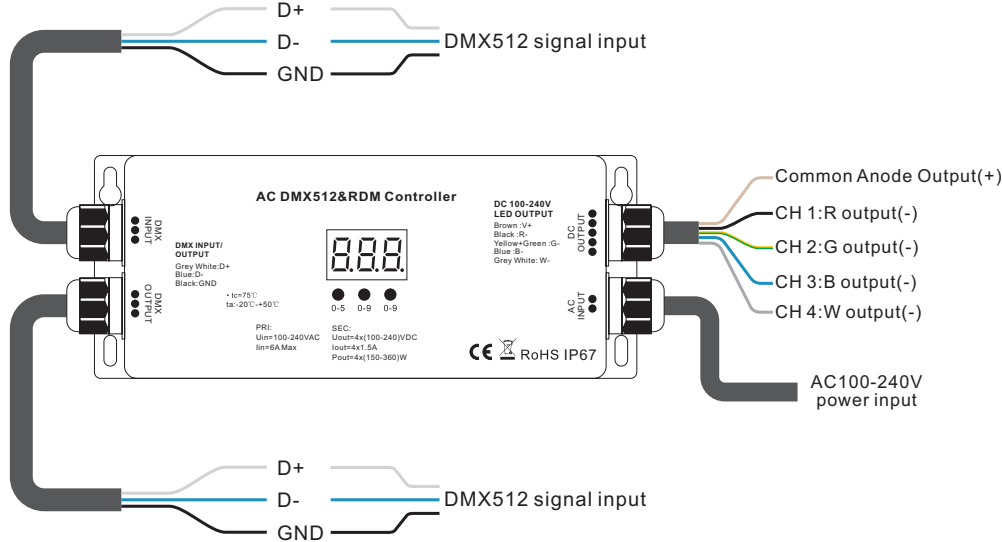

Product Data

Input Voltage	Output Voltage	Output Current	Max Load	Size(LxWxH)	Ambient Temp.
AC 100-240V	DC 100-240V	Max. 4x1.5A	660W@110V 1320W@220V	180.5x73.6x38mm	-20°C~+50°C

- RDM enabled DMX high voltage LED strip controller
- Output for high voltage DC100~240V LED Strip
- Standard DMX512 compliant control interface
- RDM function enabled to realize intercommunication between DMX master and decoder.
- For example, DMX decoder's address can be assigned by DMX master console
- With digital display to show data directly, easily to set and show DMX address.
- Total 4 channels LED output, common anode
- DMX address manually settable
- DMX channel quantity from 1CH~4CH settable
- Output PWM frequency from 500HZ ~ 35K HZ settable, but do not set it higher than 3KHz.
- Output dimming curve gamma value from 0.1 ~ 9.9 settable
- Waterproof grade:IP67

Safety & Warnings

- DO NOT install with power applied to device.
- This device is IP67 rating and protected against damp environment.

Operation

To set desired DMX512 address through buttons, **button A** is to set "hundreds" position, **button B** is to set "tens" position, **button C** is to set "unit" position.



Set DMX address (Factory default DMX address is 001)

Press and hold down any of the 3 buttons for over 3 seconds, digital display flashes to enter into address setting, then keep short pressing button A to set "hundreds" position, button B to set "tens" position, button C to set "units" position, then press and hold down any button for >3 seconds to confirm the setting.



DMX signal indicator ● : When DMX signal input is detected, the indicator on the display following after the digit of "hundreds" position of DMX address turns on red ●●●.



Choose DMX Channel (Factory default DMX channel is 4CH)

Press and hold down both buttons B+C simultaneously for over 3 seconds, CH digital display flashes, then keep short pressing button A to choose 1/2/3/4, which means total 1/2/3/4 channels. Press and hold down button A for >3 seconds to confirm the setting. Factory default is 4 DMX channels.

For example the DMX address is already set as 001.

1CH=1 DMX address for all the output channels, which all will be address 001.

2CH=2 DMX addresses, output 1&3 will be address 001, output 2&4 will be address 002

3CH=3 DMX addresses, output 1, 2 will be address 001, 002 respectively, output 3&4 will be address 003

4CH=4 DMX addresses, output 1, 2, 3, 4 will be address 001, 002, 003, 004 respectively



Choose PWM frequency (Factory default PWM frequency is PF1 1KHz)

Press and hold down both buttons A+B simultaneously for over 3 seconds, digital display will show PF1, PF means output PWM frequency, the digit 1 will flash, which means frequency, then keep short pressing button C to select a frequency from 0-9 and A-J, which stand for following frequencies:

0=500Hz, 1=1KHz, 2=2KHz, ..., 9=9KHz, A=10KHz, B=12KHz, C=14KHz, D=16KHz, E=18KHz, F=20KHz, H=25KHz, J=35KHz.

Then press and hold down button C for >3 seconds to confirm the setting.

Note: DO NOT set the PWM frequency higher than 3KHz to avoid over heat and damage to the device.

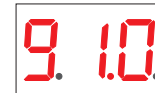

Choose Dimming Curve Gamma Value (Factory default dimming curve value is g1.0)

Press and hold down all buttons A+B+C simultaneously for over 3 seconds, digital display flashes g1.0, 1.0 means the dimming curve gamma value, the value is selectable from 0.1-9.9, then keep short pressing button B and button C to select corresponding digits, then press and hold down both buttons B+C for >3 seconds to confirm the setting.

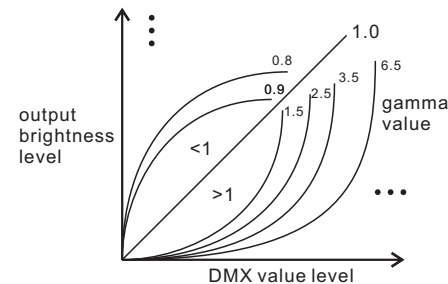

Restore to Factory Default Setting

Press and hold down both buttons A+C for over 3 seconds until the digital display turns off and then turns on again, all settings will be restored to factory default.

Default settings are as follows:

DMX Address: 001

DMX Address Quantity: 4CH

PWM Frequency: PF1

Gamma: g1.0

The supported RDM PIDs are as follows:

DISC_UNIQUE_BRANCH

DISC_MUTE

DISC_UN_MUTE

DEVICE_INFO

DMX_START_ADDRESS

IDENTIFY_DEVICE

SOFTWARE_VERSION_LABEL

DMX_PERSONALITY

DMX_PERSONALITY_DESCRIPTION

SLOT_INFO

SLOT_DESCRIPTION

MANUFACTURER_LABEL

SUPPORTED_PARAMETERS

Wiring diagram

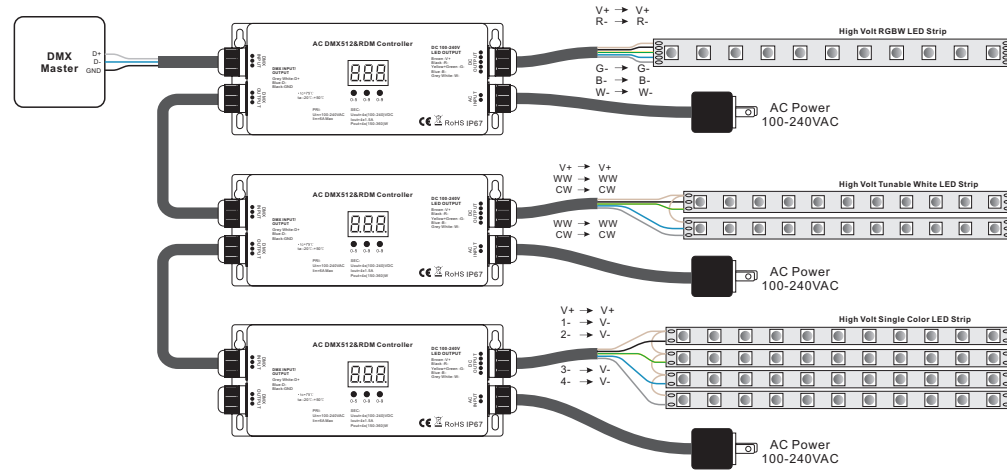

Product Dimension

